

PL	Instrukcja montażu	UA	Інструкція по установці
GB	Assembly instruction	H	Szerelési útmutató
D	Montageanleitung	RO	Instructiuni de montaj
SK	Návod na inštaláciu	FR	Instruction de montage
CZ	Pokyny k instalaci	IT	Istruzioni di montaggio
RUS	Инструкция по установке	ES	Instrucciones de ensamblaje
		AE	تعليمات التجميع

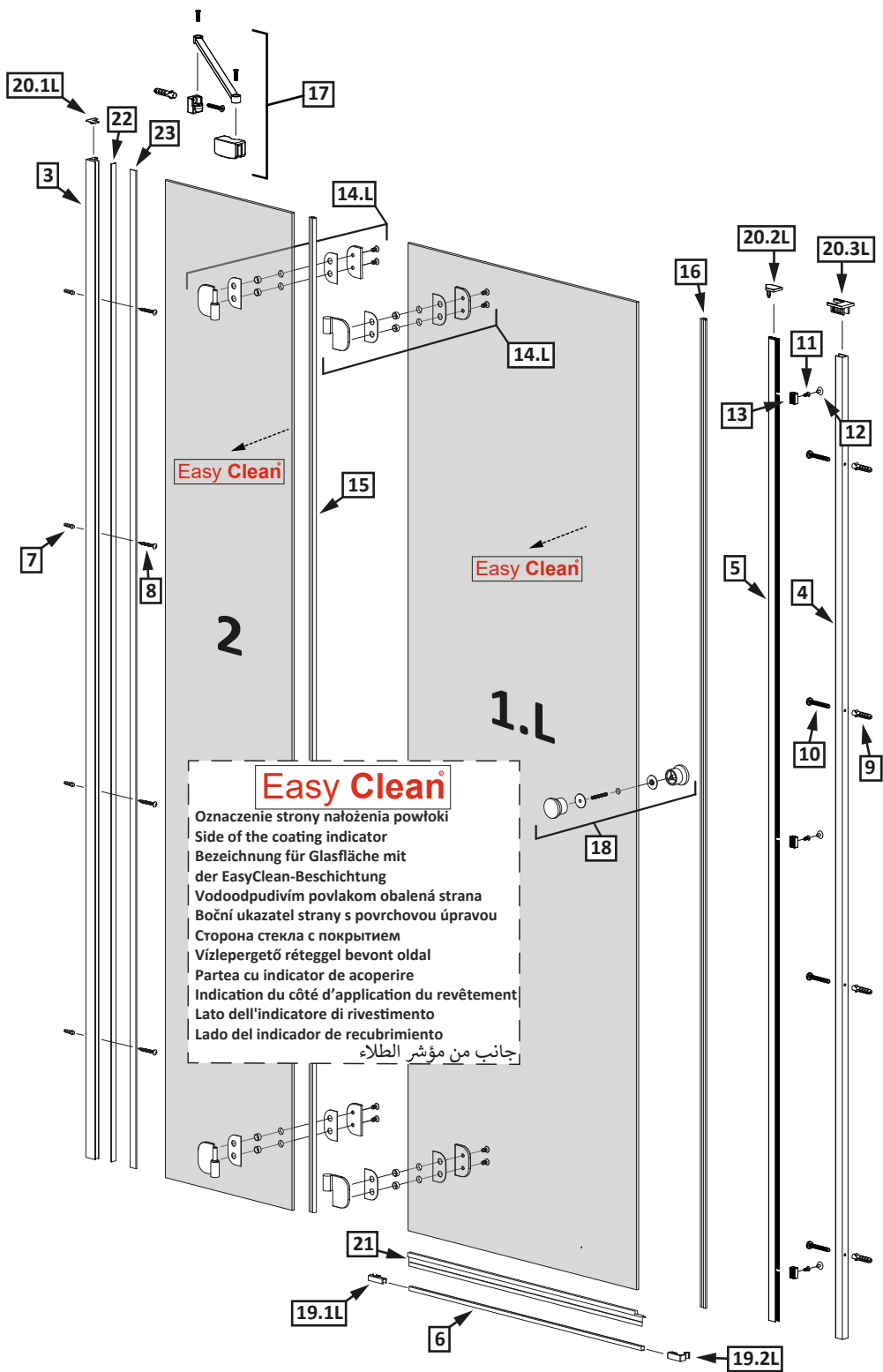

Torrenta DWJ

- PL** Instrukcja pokazuje montaż kabiny w wariacie lewym
- GB** Assembling instruction shows installation of left-side version
- D** Die Montageanleitung stellt die linke Variante der Dusche dar
- SK** Návod na inštaláciu sa vzťahuje na ľavé prevedenie
- CZ** Návod zobrazuje instalaci sprchového koutu vlevo
- RUS** В инструкции указан монтаж левого варианта кабины
- UA** В інструкції вказаний монтаж лівого варіанту kabini
- RO** Instructiunile de montaj se refera la instalarea cu deschidere pe stanga
- H** A szerelési útmutató balos verzióra vonatkozik
- FR** L'instruction montre un montage en version gauche
- IT** Le istruzioni di montaggio mostrano l'installazione della versione sinistra
- ES** La instrucción de montaje muestra la instalación de laversion del lado izquierdo
- AE** يوضح تجميع التعليمات التثبيت من نسخة الجانب الأيسر











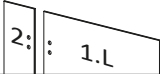





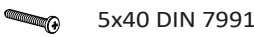

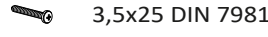
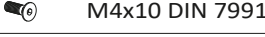

Easy Clean

Easy Clean

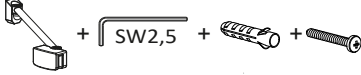

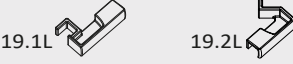

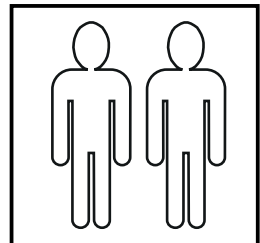
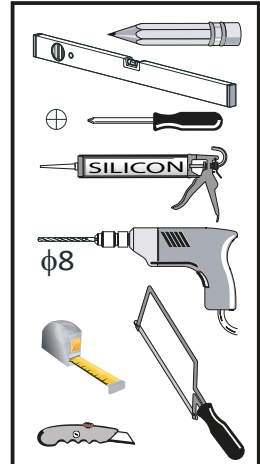

Easy Clean®

Oznaczenie strony nałożenia powłoki
 Side of the coating indicator
 Bezeichnung für Glasfläche mit
 der EasyClean-Beschichtung
 Vodoodpudivím povlakom obalená strana
 VočnÍ ukazatel strany s povrřovou úpravou
 Сторона стекла с покрытием
 Vízlepergető réteggel bevont oldal
 Partea cu indicator de acoperire
 Indication du côté d'application du revêtement
 Lato dell'indicatore di rivestimento
 Lado del indicador de recubrimiento
 جانب من مؤشر الطلاء

Nr Nr No. číslo počet No Sorszám Numar N° N° N° رقم	Oznaczenie Mark Bezeichnung Označenje Označení oboznačenje Jelölés Componenta Symbole Simbolo Símbolo علامة	Sztuk Pcs. Stück Kus KS штук Db. Bucati Pcs Pz Pzas قطع
1.L 2.		1 1
3.		1
4.		1
5.		1
6.		1
7.		4
8.		4
9.		4
10.		4
11.		3
12.		3
13.		3
14.L	 SW4 + SW2	2
15.		1
16.		1
17.		1
18.		1
19.1L 19.2L		1 1
20.1L 20.2L 20.3L		1 1 1

Montaż z listwą progową
Installation with threshold profile
Die Montage mit Schwalleiste
Montovanie s prahovým profilom
Instalace přechodové lišty
Montaż s profilem progu
Szerelés küszöb profilal
Instalarea cu profil prag
Montage avec barre de seuil
Installazione con profilo di soglia
Instalación con la barra de umbral
تجميع مع شريط



Nr Nr No. číslo počet No Sorszám Numar N° N° N° رقم	Oznaczenie Mark Bezeichnung Označenje Označení обозначение Jelölés Componenta Symbole Simbolo Símbolo علامة	Sztuk Pcs. Stück Kus KS штук Db. Bucati Pcs Pz Pzas قطع
21.		1
22.		1
23.	 L = 1970mm	1
24.	 + 	2
25.		4

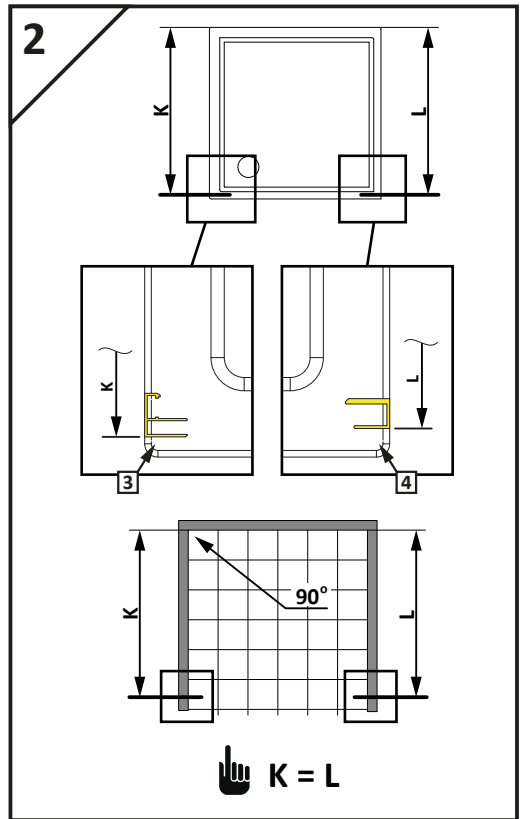
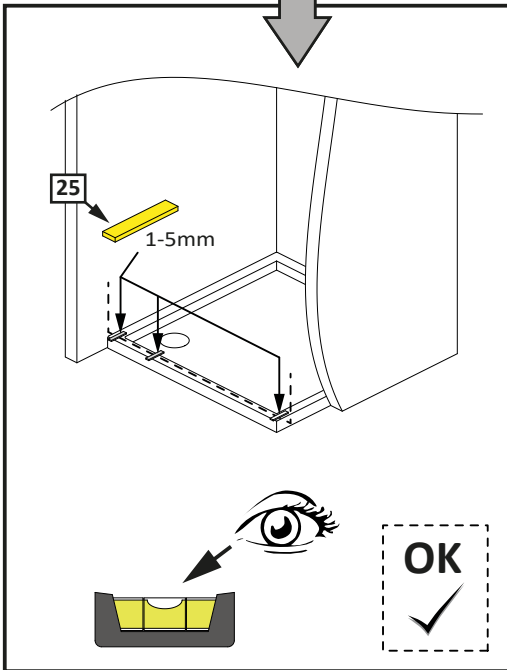
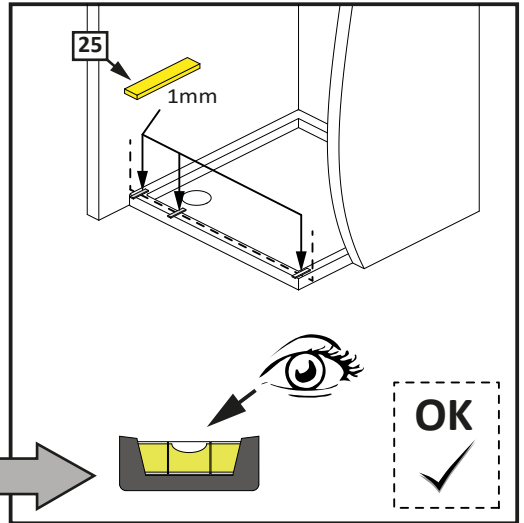
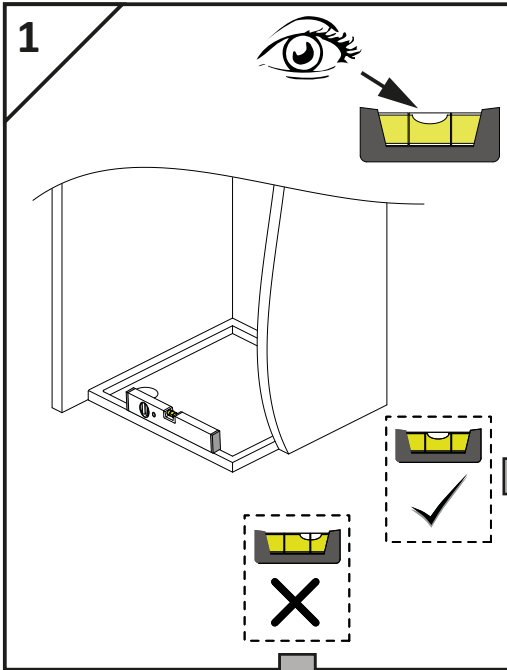

2.1

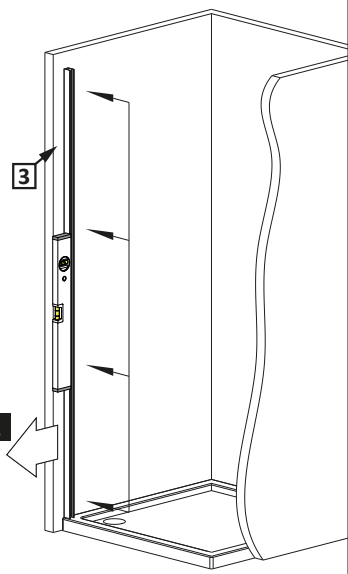
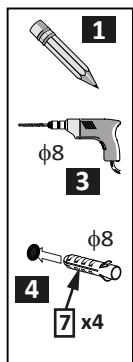

2.2

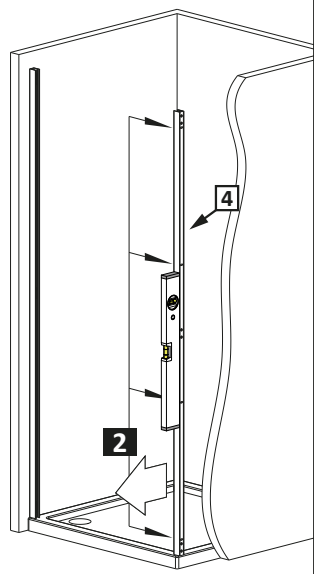
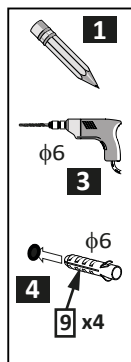

2.3

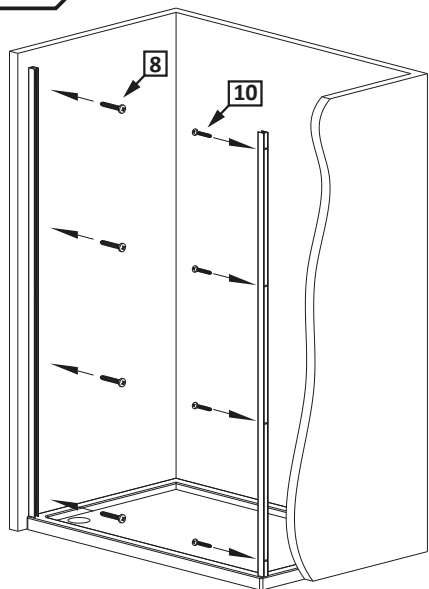

3

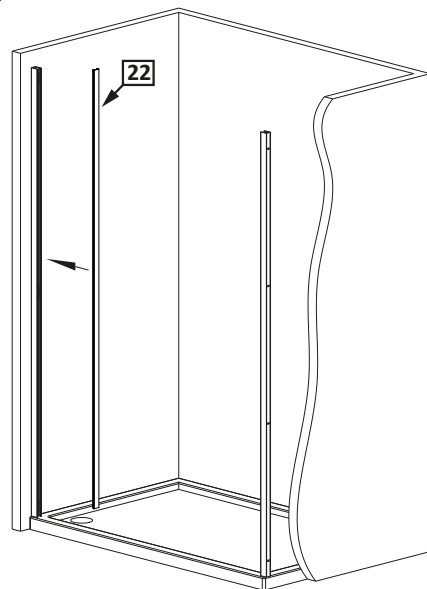

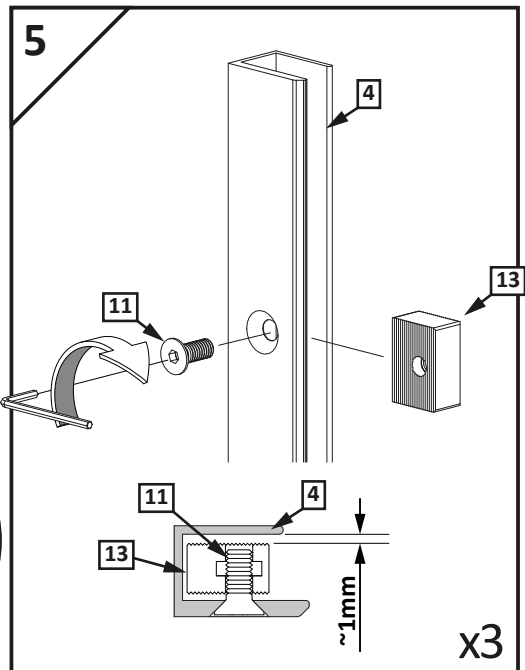
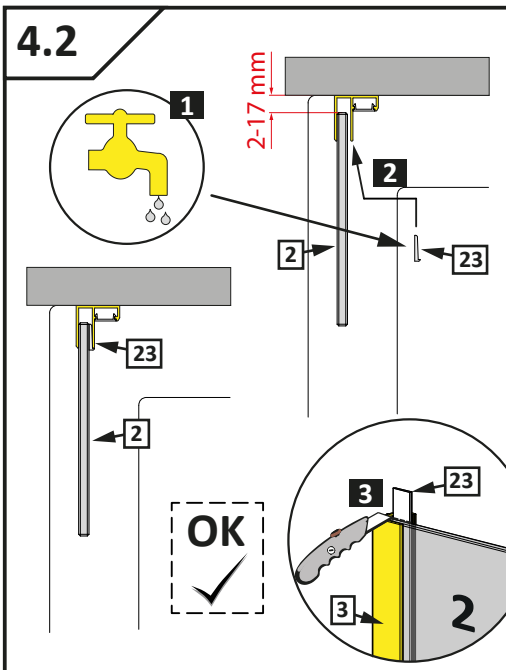
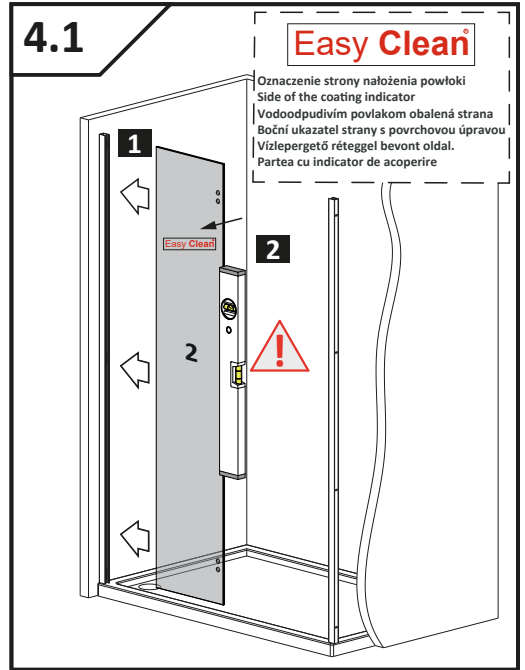
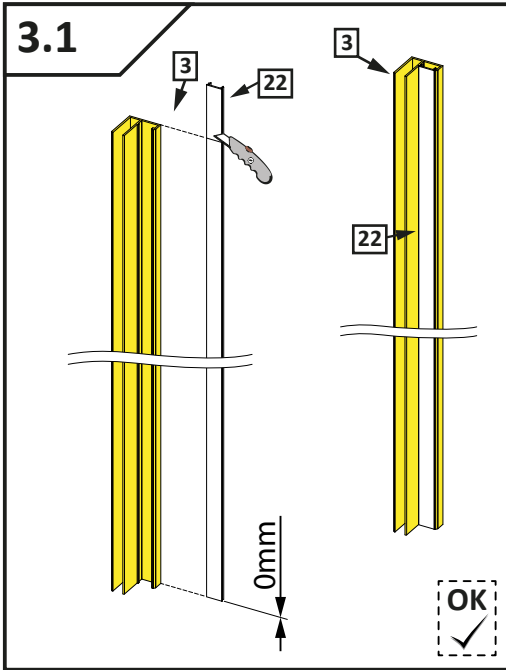

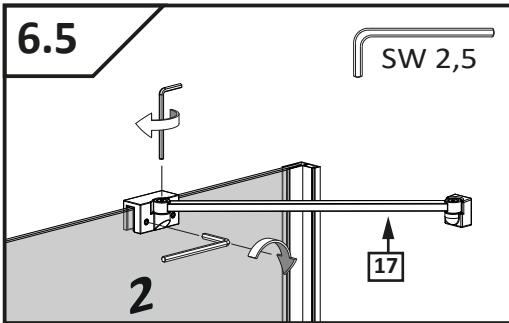
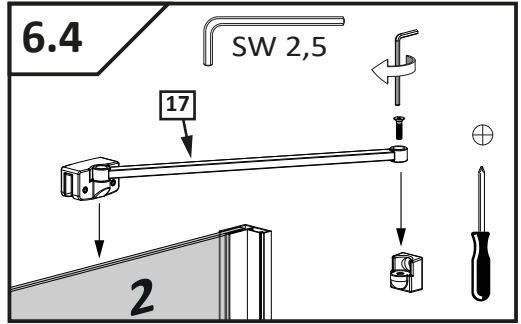
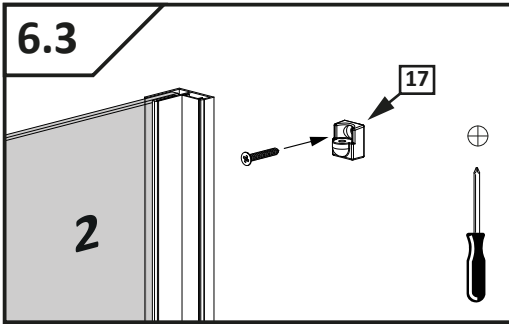
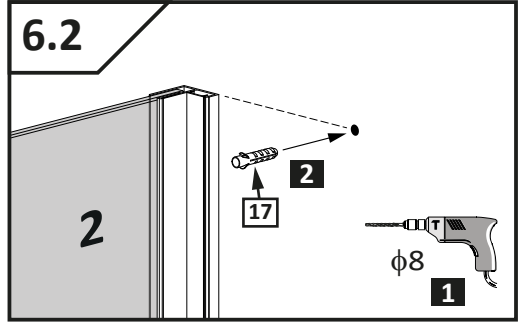
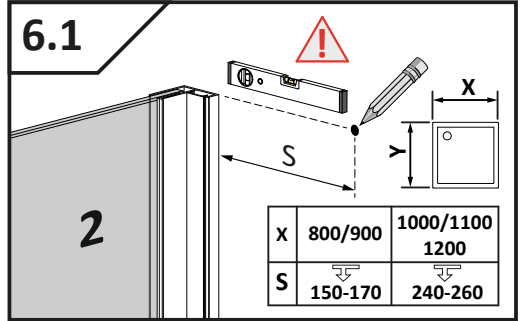
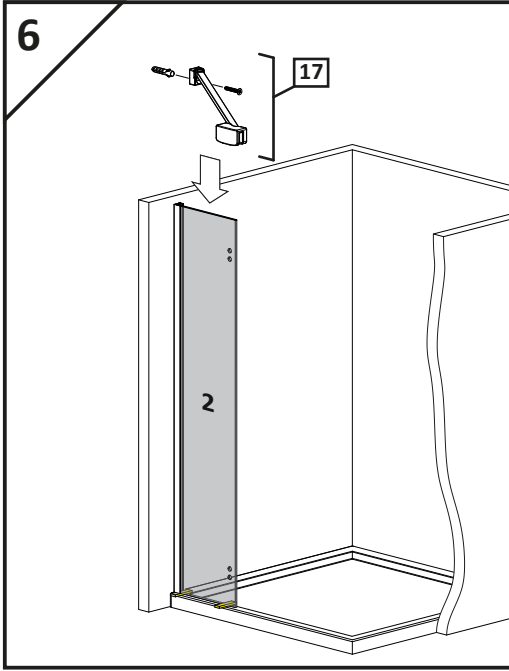

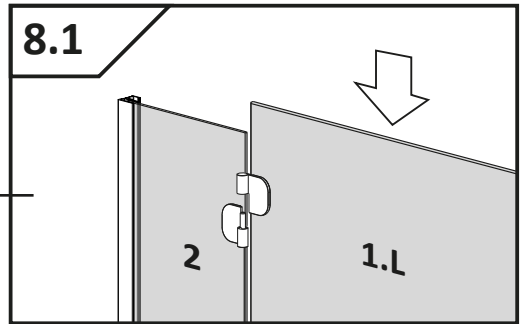
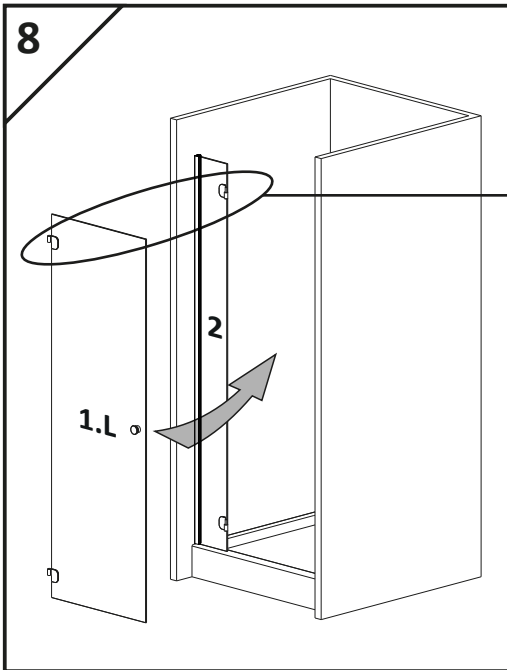
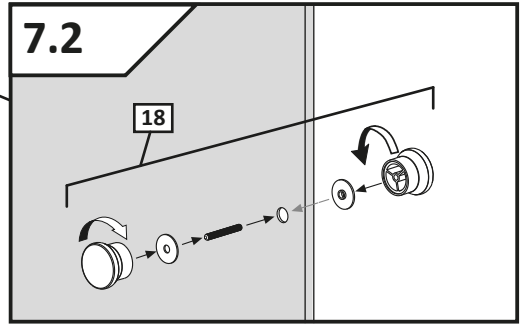
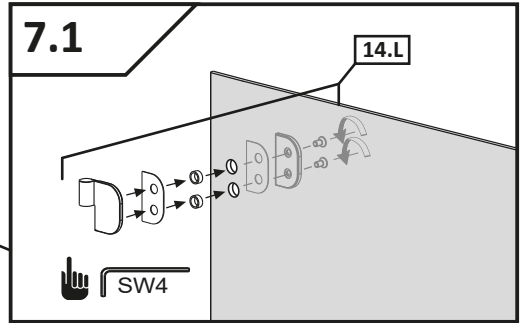
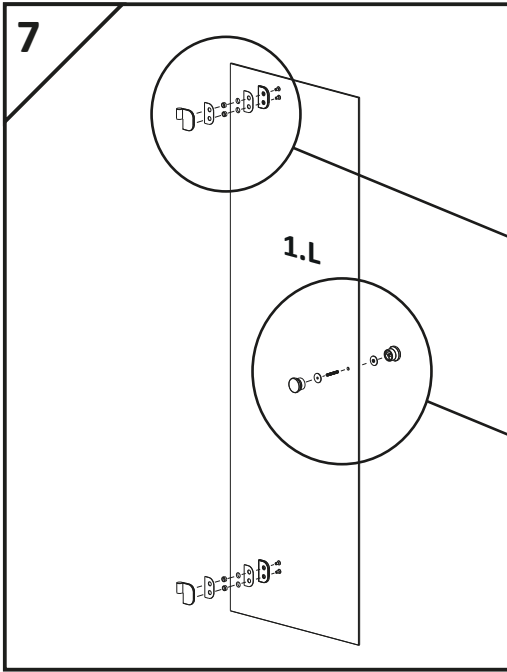

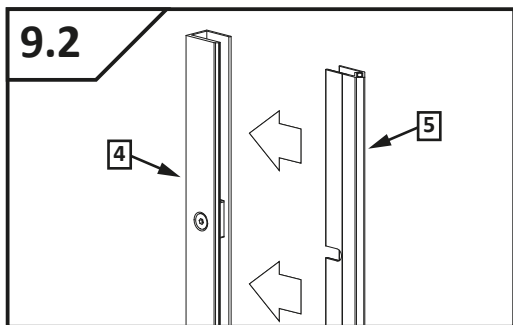
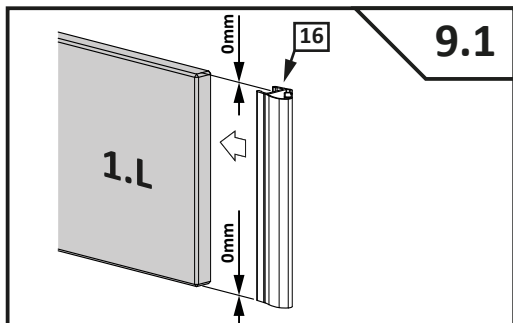
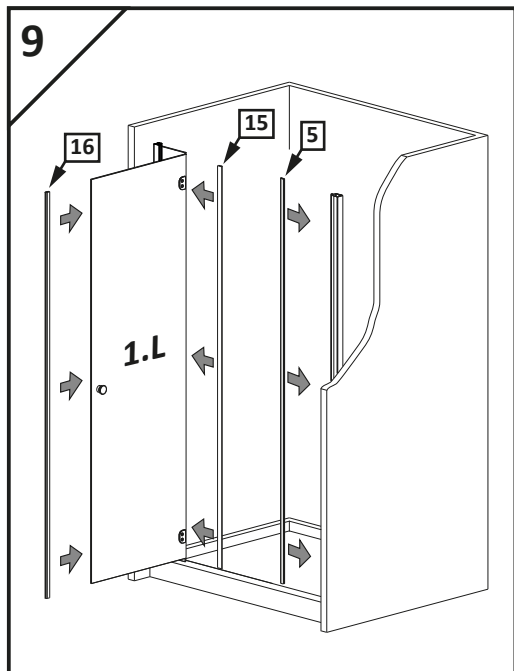

Montaž z listwą progową
 Installation with threshold profile
 Die Montage mit Schwalleiste
 Montovanie s prahovým profilom
 Instalace přechodové lišty
 Монтаж с профилем порога
 Szerelés küszöb profilal
 Instalarea cu profil prag
 Montage avec barre de seuil
 Installazione con profilo di soglia
 Instalación con la barra de umbral
 تجميع مع شريط عتبة

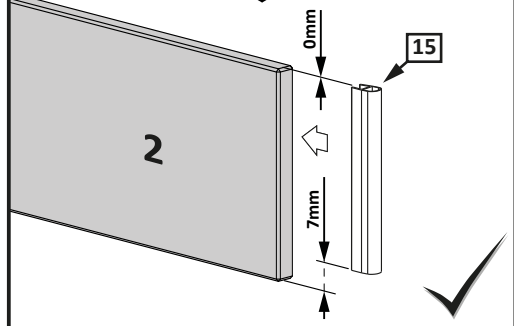

Montaž bez listwy progowej
 Installation without threshold profile
 Die Montage ohne Schwalleiste
 Montovanie bez prahového profilu
 Instalace bez prahové lišty
 Монтаж без профиля порога
 Szerelés küszöb profil nélkül
 Instalarea fara profil prag
 Montage sans barre de seuil
 Installazione senza profilo di soglia
 Instalación sin la barra de umbral
 تجميع دون شريط عتبة

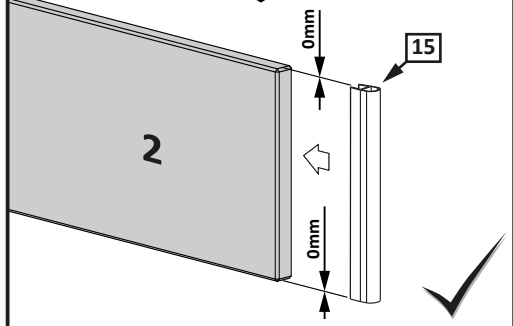

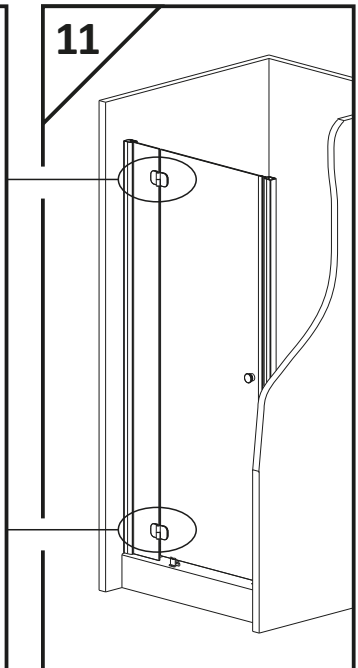
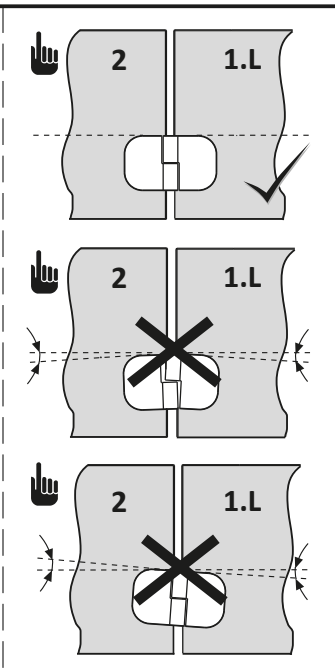
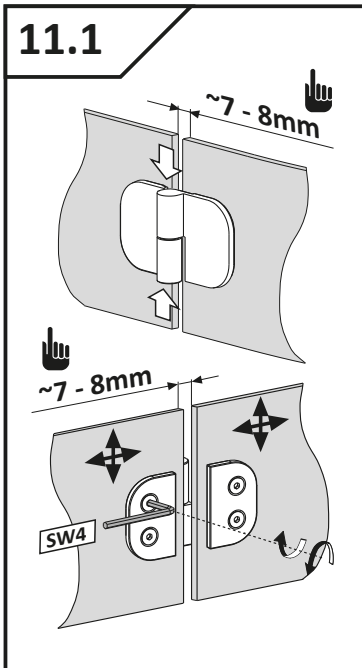
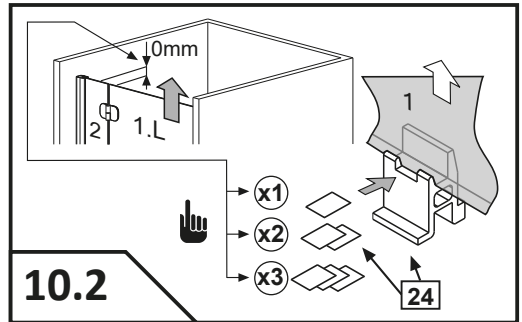
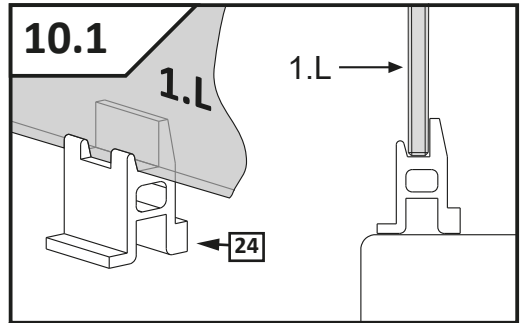
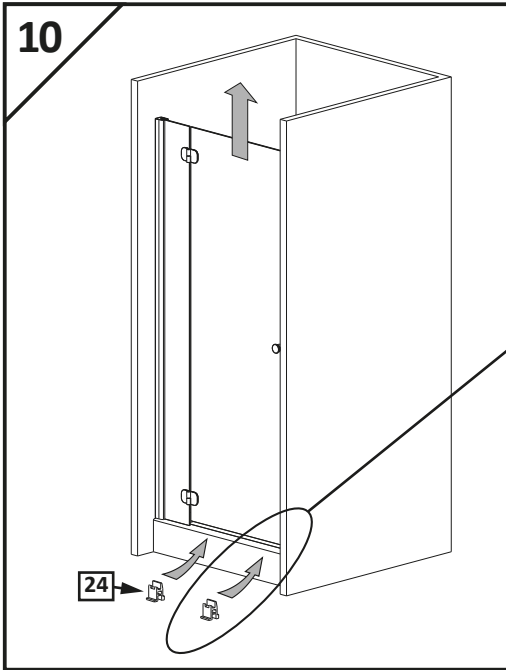

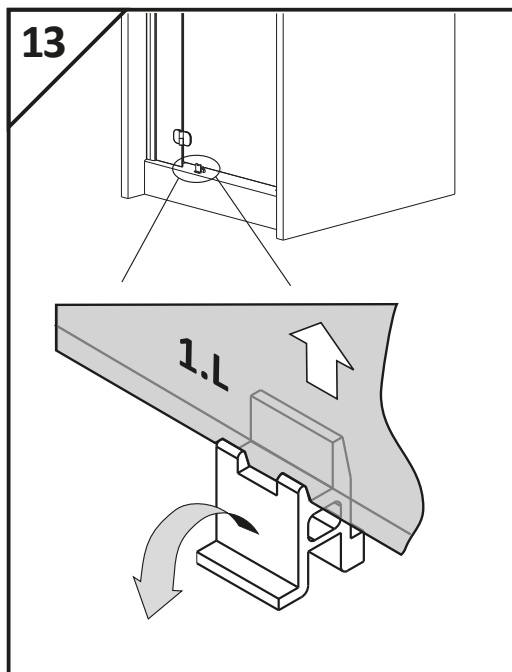
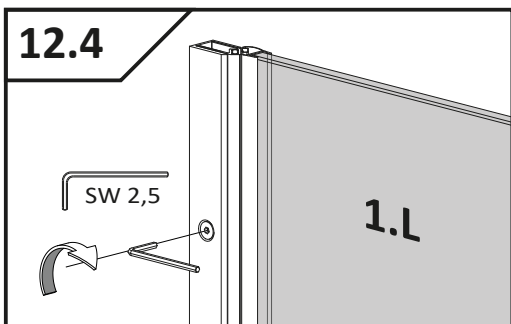
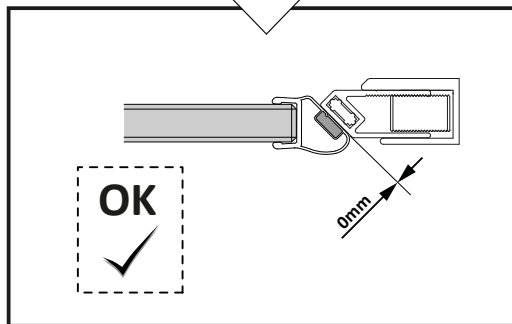
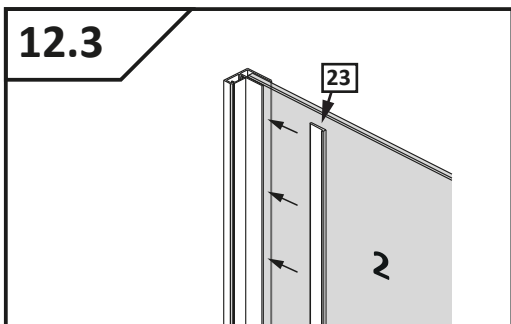
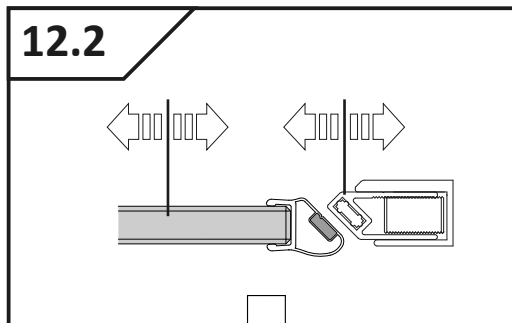
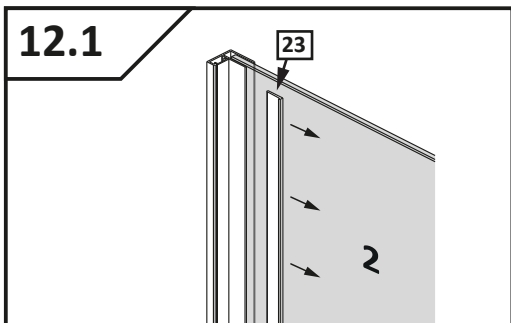

Montaż z listwą progową
Installation with threshold profile
Die Montage mit Schwalleiste
Montovanie s prahovým profilom
Instalace přechodové lišty
Монтаж с профилем порога
Szerelés küszöb profilal
Instalarea cu profil prag
Montage avec barre de seuil
Installazione con profilo di soglia
Instalación con la barra de umbral
 تجميع مع شريط عتبة

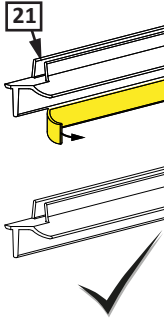

21

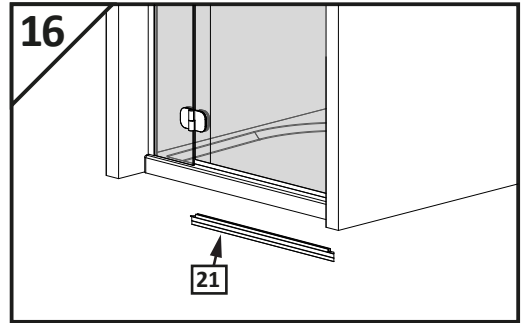

Montaż bez listwy progowej
Installation without threshold profile
Die Montage ohne Schwalleiste
Montovanie bez prahového profilu
Instalace bez prahové lišty
Монтаж без профиля порога
Szerelés küszöb profil nélkül
Instalarea fara profil prag
Montage sans barre de seuil
Installazione senza profilo di soglia
Instalación sin la barra de umbral
 تجميع دون شريط عتبة

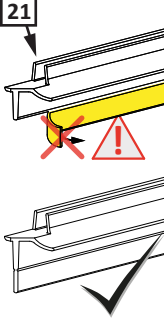

21

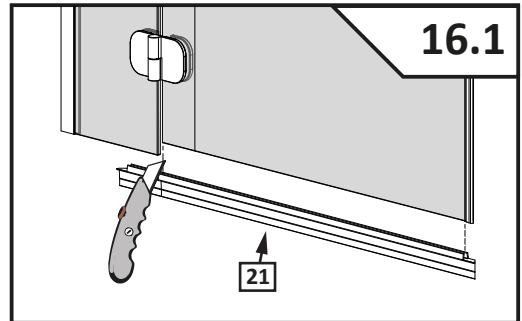

Montaż z listwą progową
Installation with threshold profile
Die Montage mit Schwalleiste
Montovanie s prahovým profilom
Instalace přechodové lišty
Монтаж с профилем порога
Szerelés küszöb profilal
Instalarea cu profil prag
Montage avec barre de seuil
Installazione con profilo di soglia
Instalación con la barra de umbral
 تجميع مع شريط عتبة

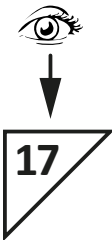

17

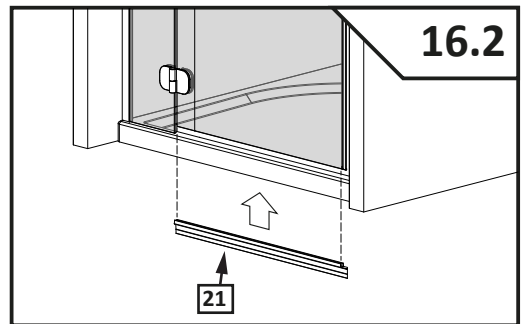

Montaż bez listwy progowej
Installation without threshold profile
Die Montage ohne Schwalleiste
Montovanie bez prahového profilu
Instalace bez prahové lišty
Монтаж без профиля порога
Szerelés küszöb profil nélkül
Instalarea fara profil prag
Montage sans barre de seuil
Installazione senza profilo di soglia
Instalación sin la barra de umbral
 تجميع دون شريط عتبة

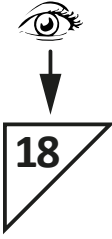

18

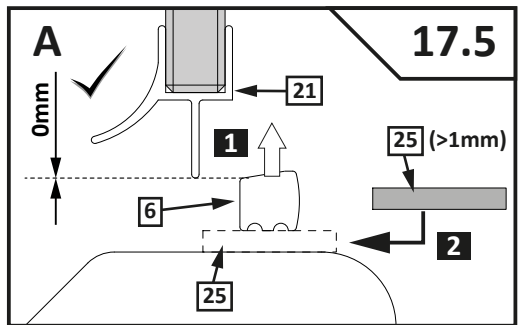
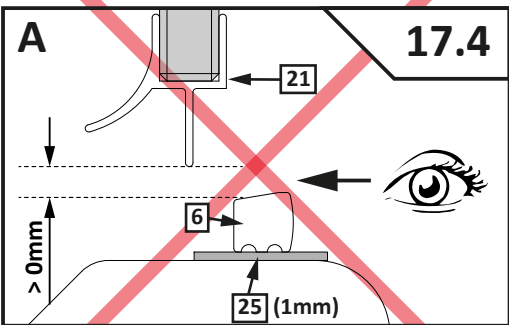
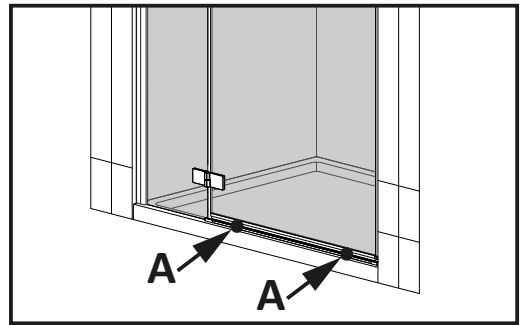
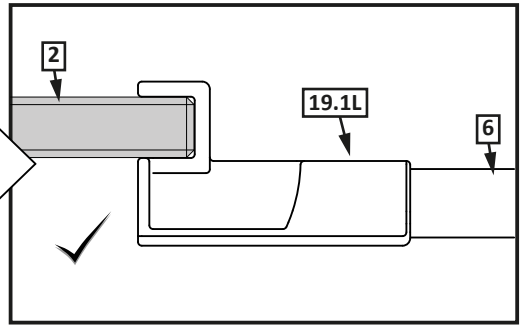
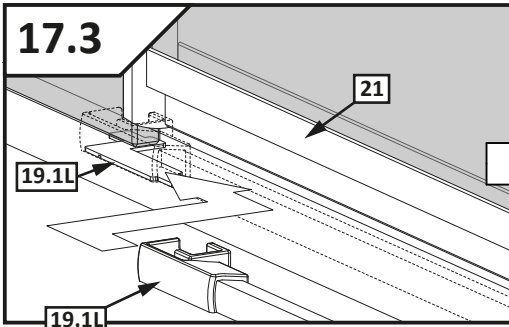
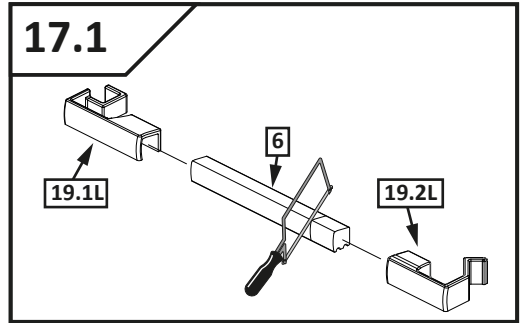
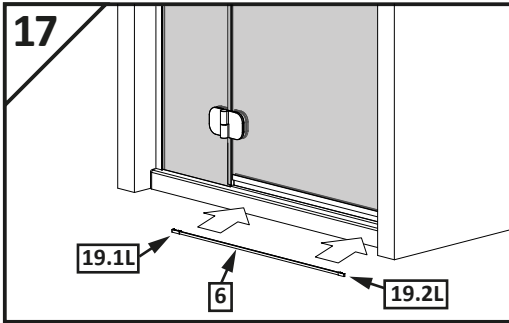

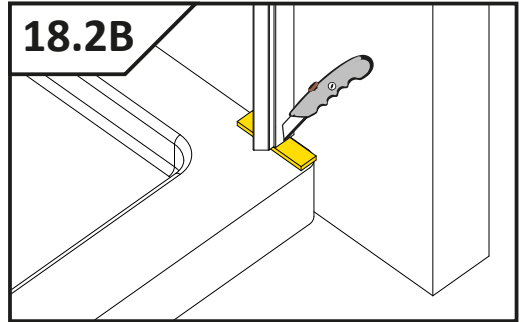
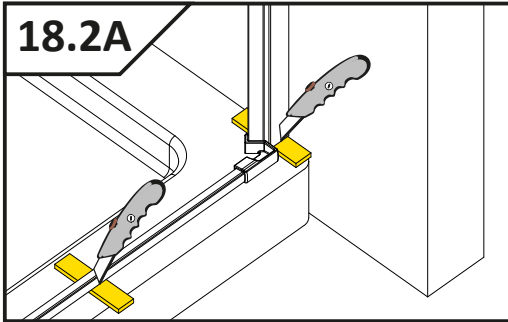
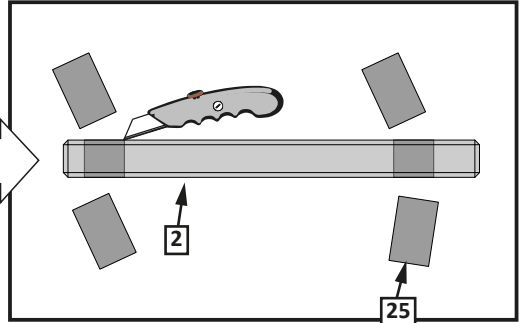
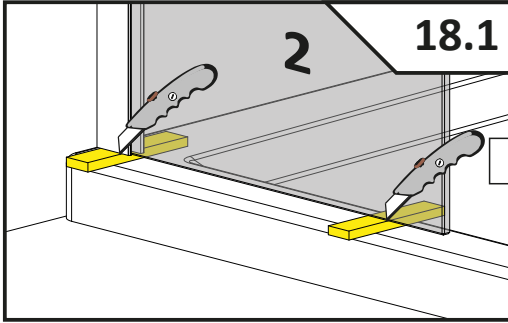

Montaż z listwą progową
Installation with threshold profile
Die Montage mit Schwalleiste
Montovanie s prahovým profilom
Instalace přechodové lišty
Монтаж с профилем порога
Szerelés küszöb profilal
Instalarea cu profil prag
Montage avec barre de seuil
Installazione con profilo di soglia
Instalación con la barra de umbral
 تجميع مع شريط عتبة



19

Montaż bez listwy progowej
Installation without threshold profile
Die Montage ohne Schwalleiste
Montovanie bez prahového profilu
Instalace bez prahové lišty
Монтаж без профиля порога
Szerelés küszöb profil nélkül
Instalarea fara profil prag
Montage sans barre de seuil
Installazione senza profilo di soglia
Instalación sin la barra de umbral
 تجميع دون شريط عتبة



20

19



24h

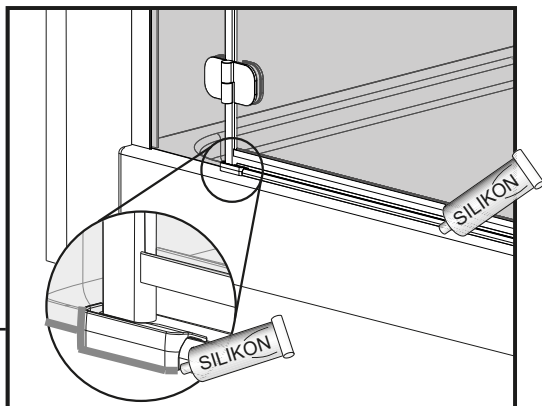
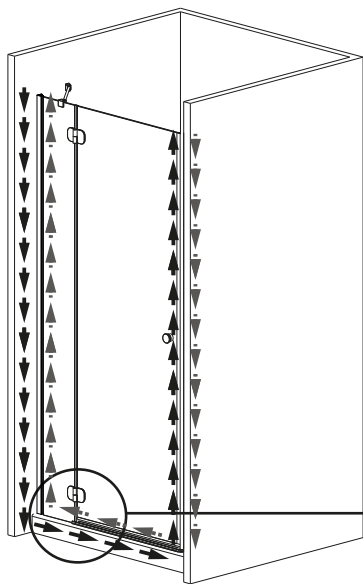

20



24h

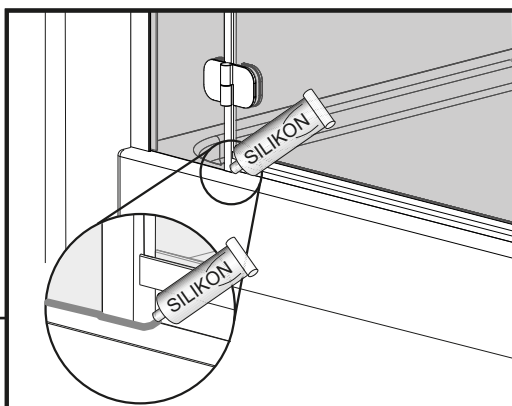
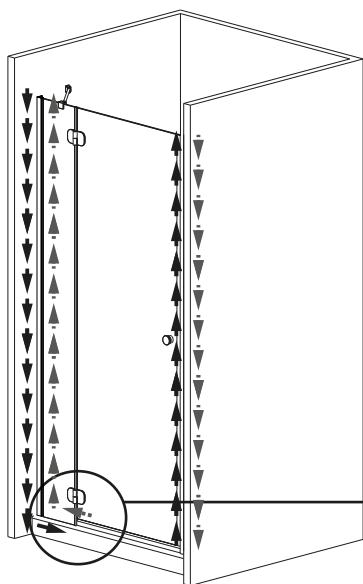

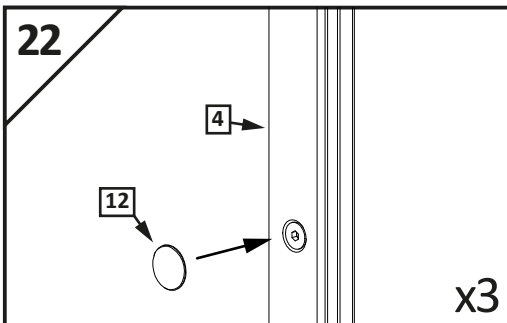
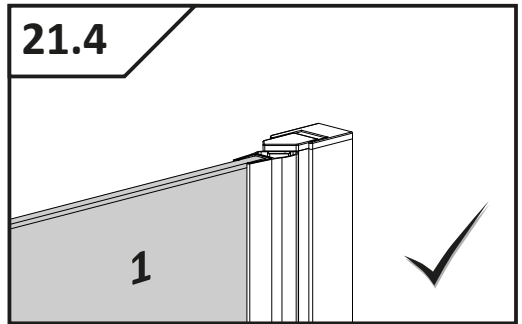
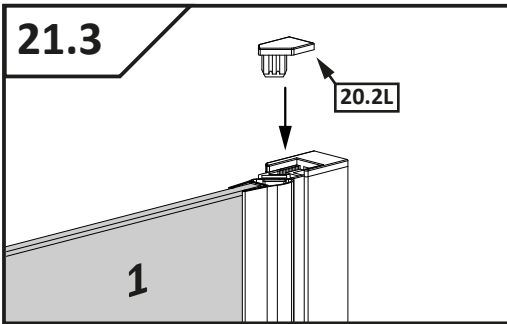
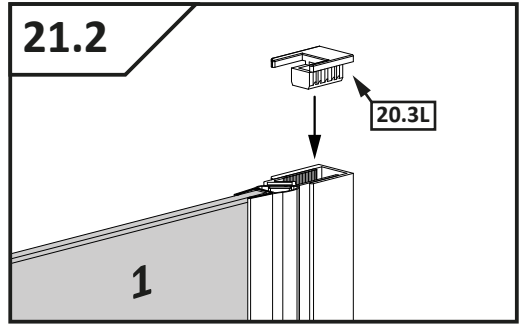
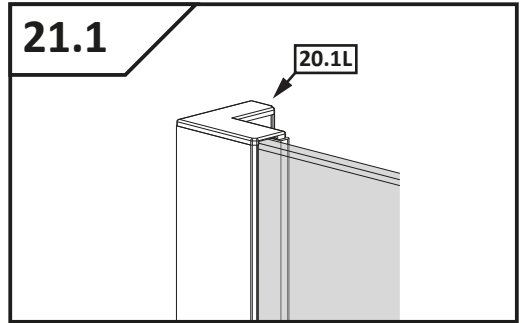
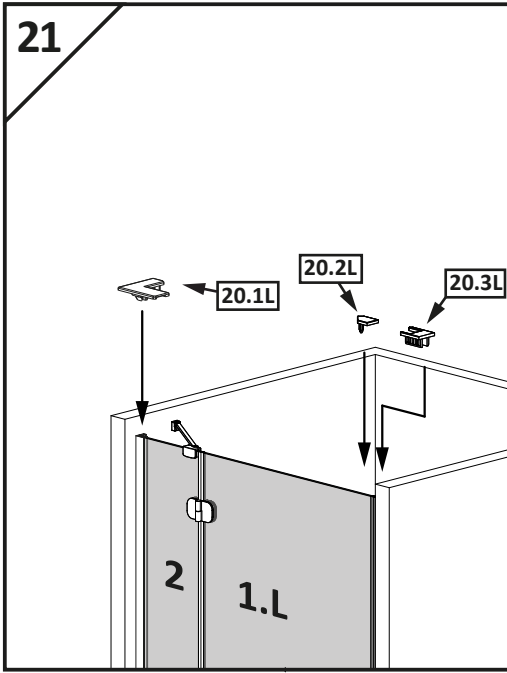

PL	Instrukcja montażu	UA	Інструкція по установці
GB	Assembly instruction	H	Szerelési útmutató
D	Montageanleitung	RO	Instructiuni de montaj
SK	Návod na inštaláciu	FR	Instruction de montage
CZ	Pokyny k instalaci	IT	Istruzioni di montaggio
RUS	Инструкция по установке	ES	Instrucciones de ensamblaje
		AE	تعليمات التجميع

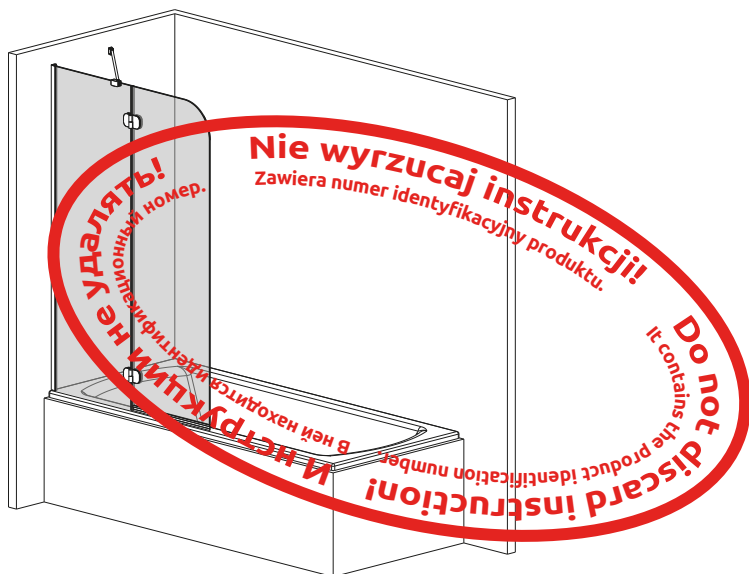





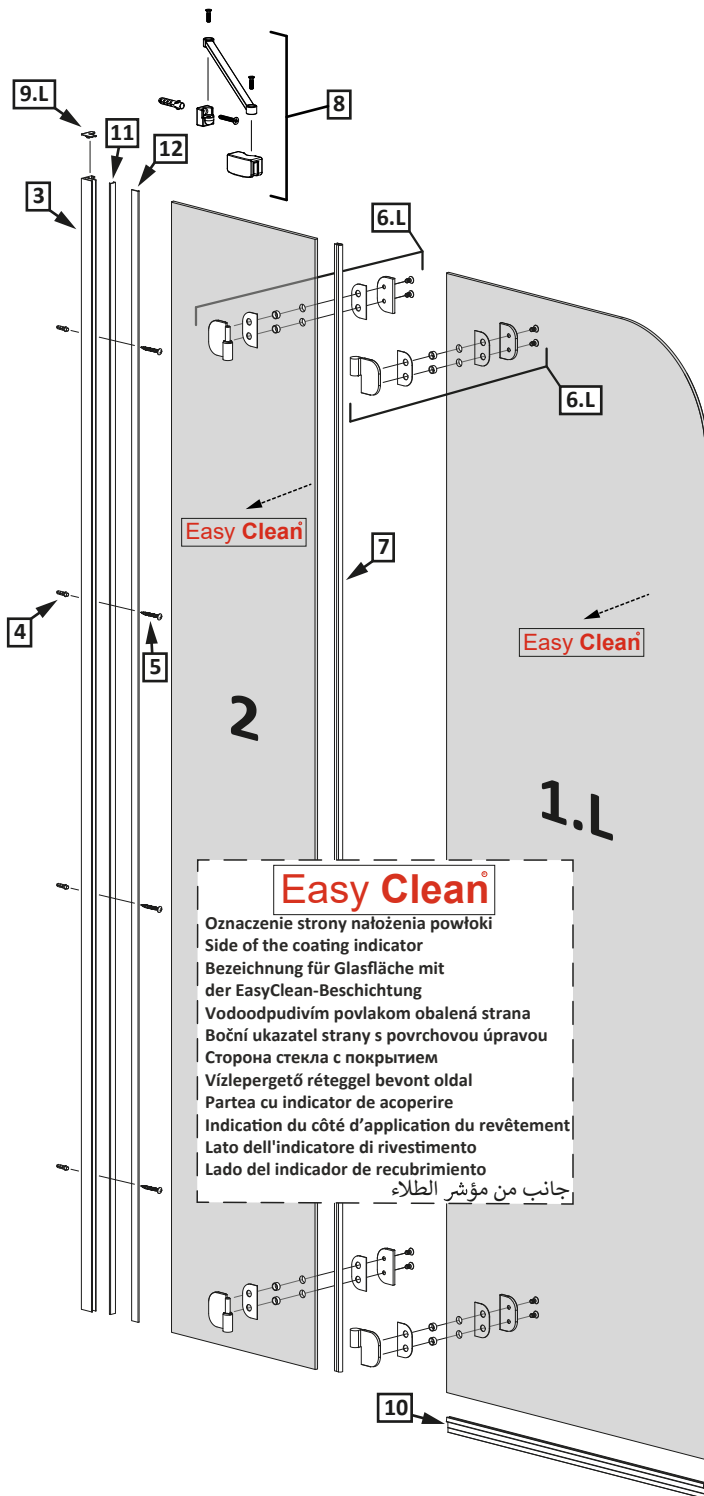





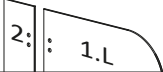













Torrenta PND II

PL	Instrukcja pokazuje montaż kabiny w wariacie lewym
GB	Assembling instruction shows installation of left-side version
D	Die Montageanleitung stellt die linke Variante der Dusche dar
SK	Návod na inštaláciu sa vzťahuje na ľavé prevedenie
CZ	Návod zobrazuje instalaci sprchového koutu vlevo
RUS	В инструкции указан монтаж левого варианта кабины
UA	В інструкції вказаний монтаж лівого варіанту kabіни
RO	Instructiunile de montaj se refera la instalarea cu deschidere pe stanga
H	A szerelési útmutató balos verzióra vonatkozik
FR	L'instruction montre un montage en version gauche
IT	Le istruzioni di montaggio mostrano l'installazione della versione sinistra
ES	La instrucción de montaje muestra la instalación de laversion del lado izquierdo
AE	يوضح تجميع التعليمات التثبيت من نسخة الجانب الأيسر



Easy Clean®

Oznaczenie strony nalożenia powłoki
 Side of the coating indicator
 Bezeichnung für Glasfläche mit der EasyClean-Beschichtung
 Vodoodpudivím povlakom obalená strana
 Boční ukazatel strany s povrchovou úpravou
 Сторона стекла с покрытием
 Vízlepergető réteggel bevont oldal
 Partea cu indicator de acoperire
 Indication du côté d'application du revêtement
 Lato dell'indicatore di rivestimento
 Lado del indicador de recubrimiento
 جانب من مؤشر الطلاء

Nr Nr No. číslo počet No Sorszám Numar N° N° N° رقم	Oznaczenie Mark Bezeichnung Oznaczenie Označení обозначение Jelölés Componenta Symbole Simbolo Símbolo علامة	Sztuk Pcs. Stück Kus KS штук Db. Bucati Pcs Pz Pzas قطع
1.L 2.		1 1
3.		1
4.	 φ8 DIN 7981	4
5.	 5x40 DIN 7991	4
6.L	  SW4 +  SW2	2
7.		4
8.	 +  SW2,5 +  + 	1
9.L		1
10.		1
11.		1
12.	 L = 1500mm	1
13.	 +  1mm  1mm  1mm	1
14.	 1mm  2mm  3mm  4mm  5mm	4

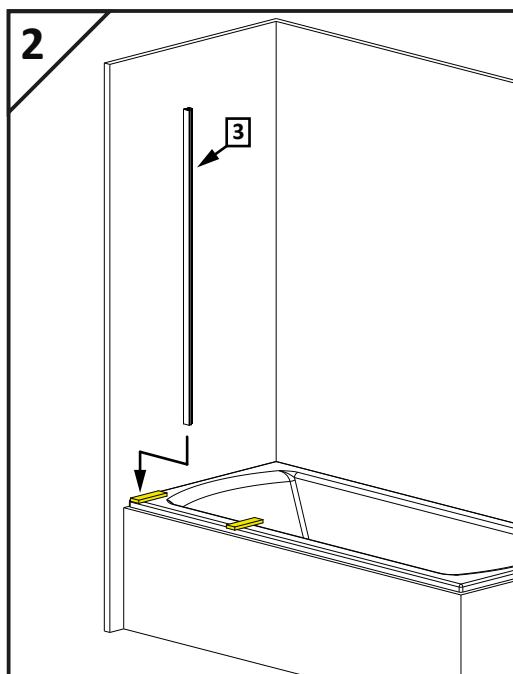
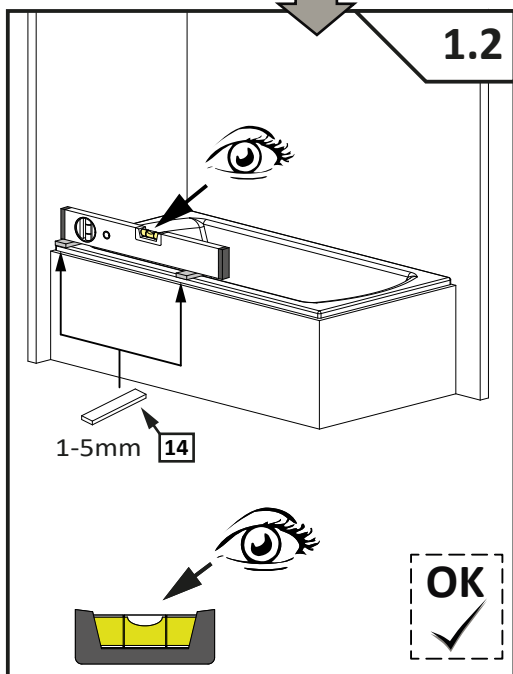
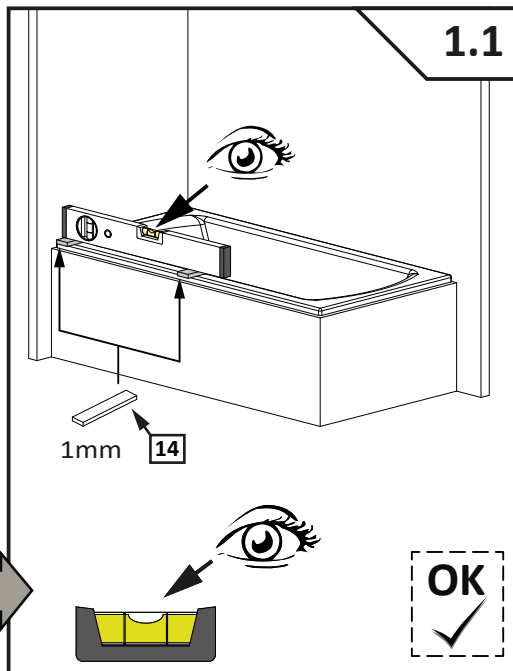
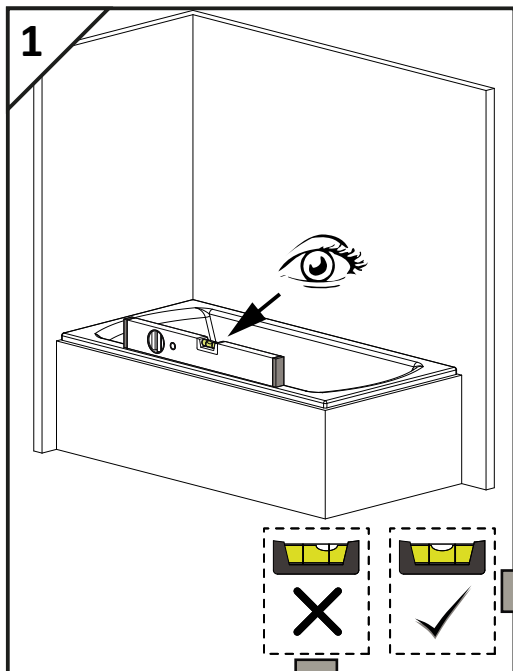

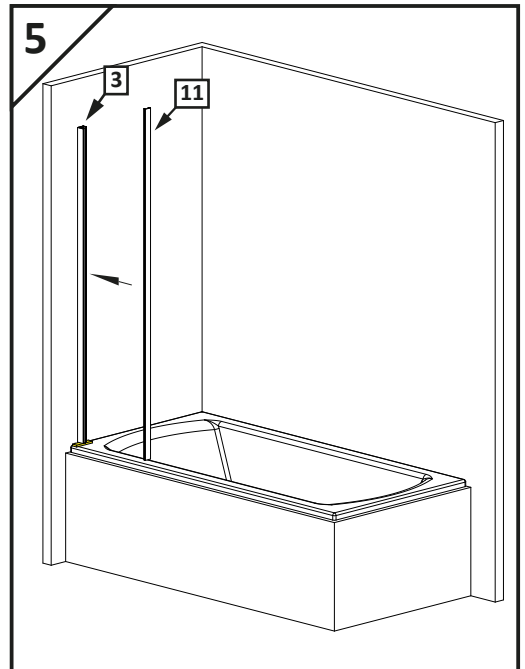
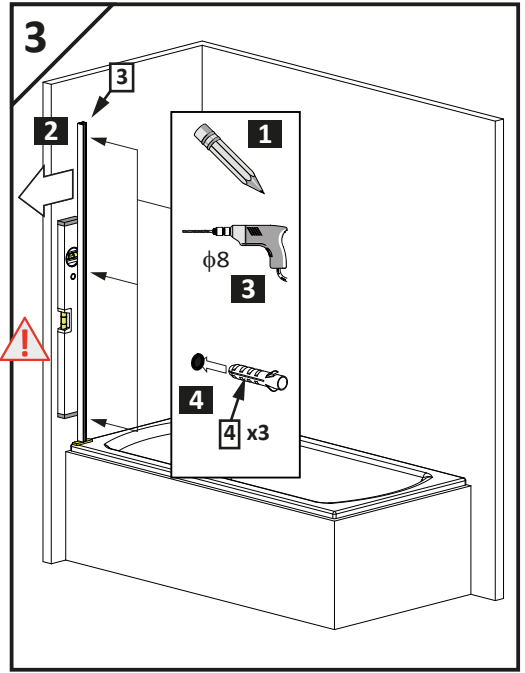
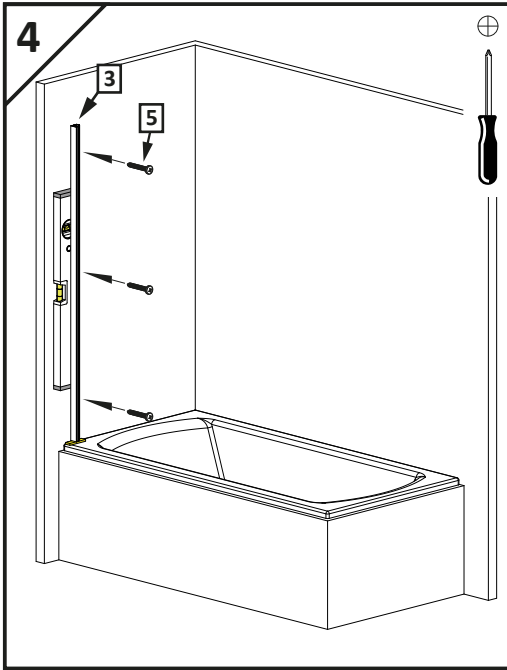
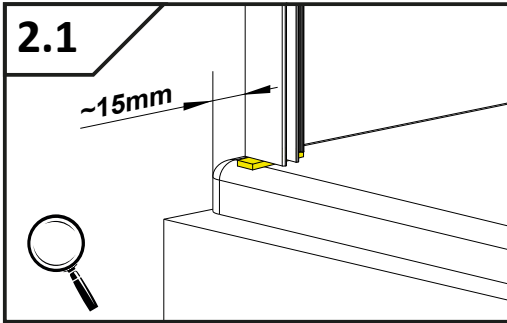

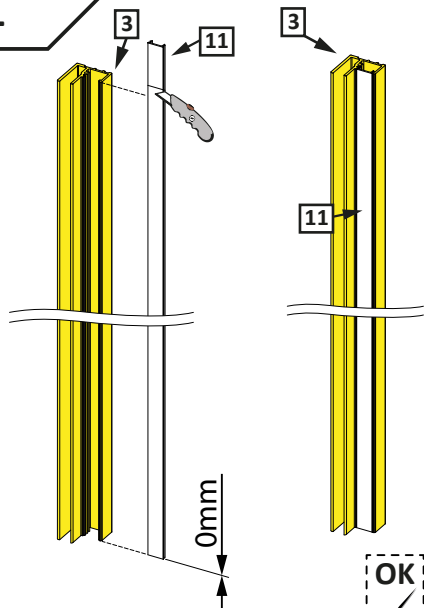
5.1**6.1****Easy Clean®**

Oznaczenie strony nałożenia powłoki
Side of the coating indicator
Vodoodpudivím povlakom obalená strana
Boční ukazatel strany s povrchovou úpravou
Vízlepergető réteggel bevont oldal.
Partea cu indicator de acoperire

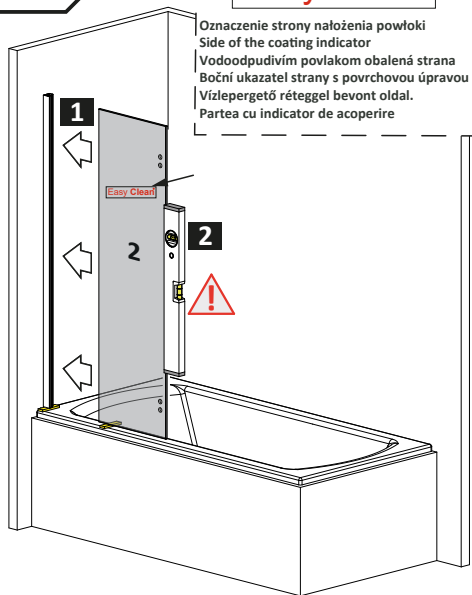
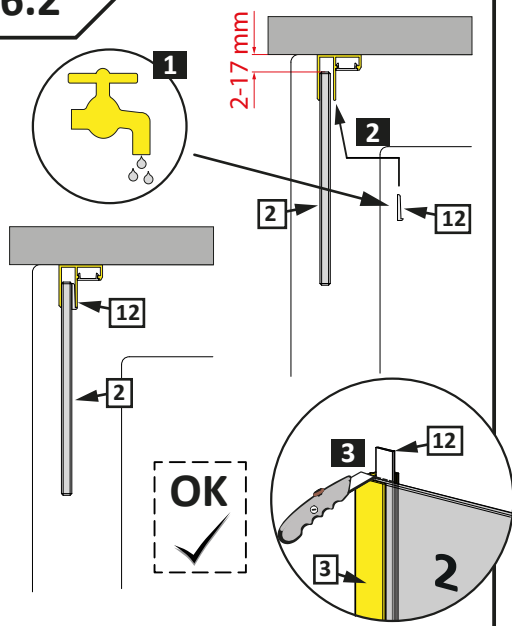
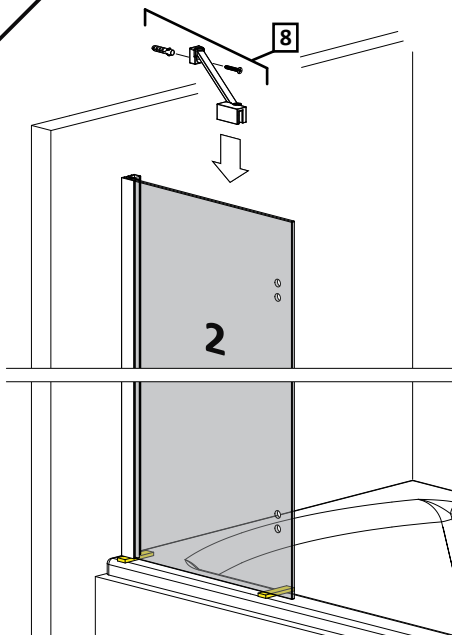
**6.2****7**

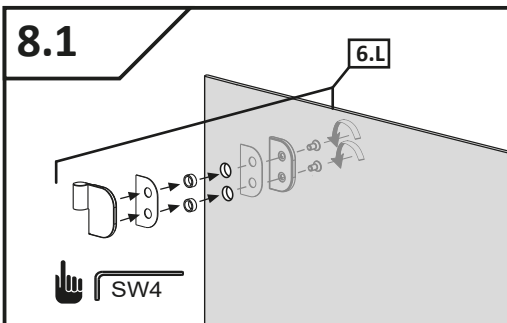
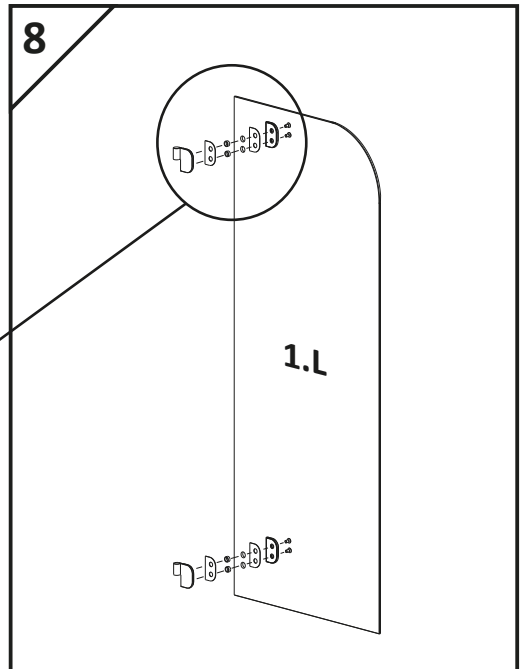
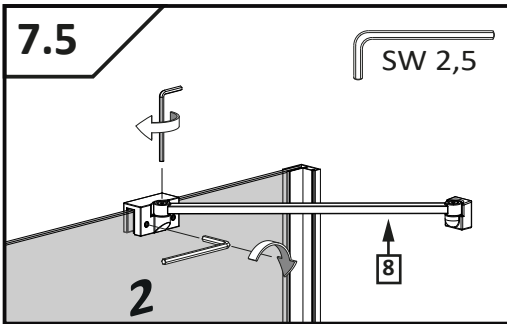
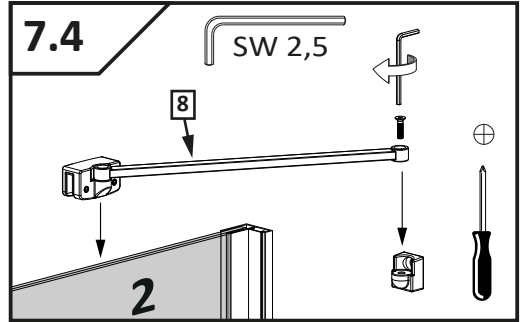
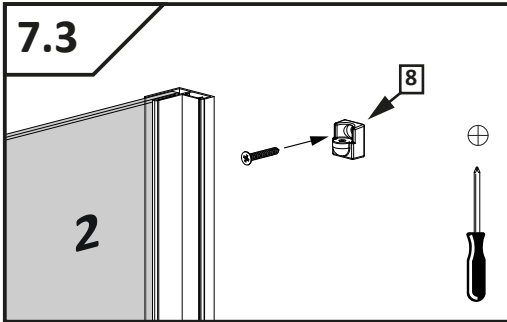
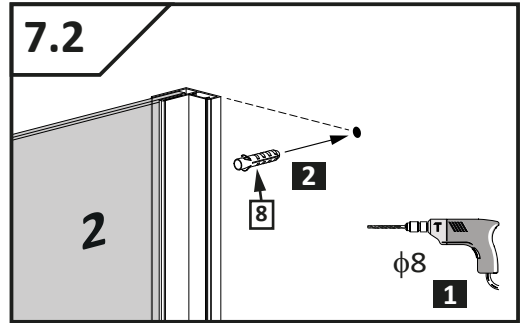
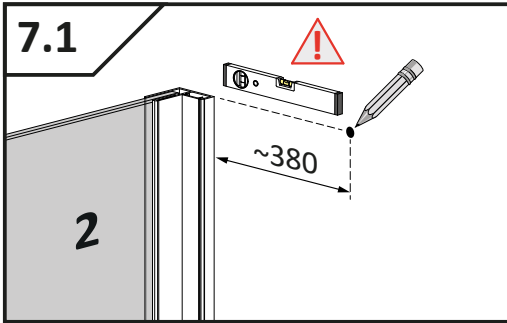

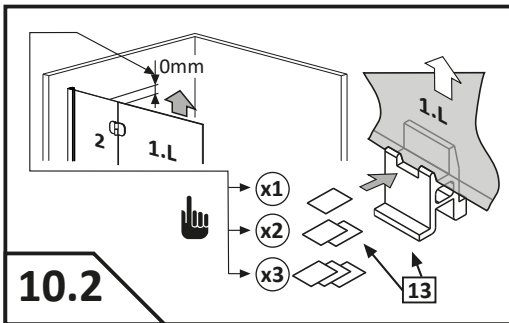
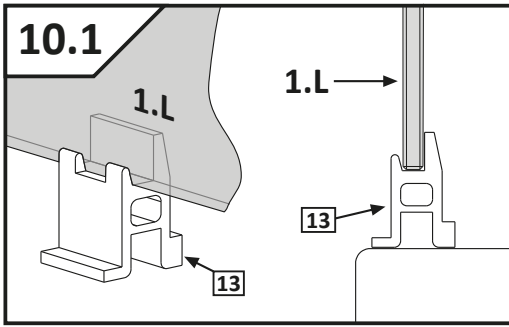
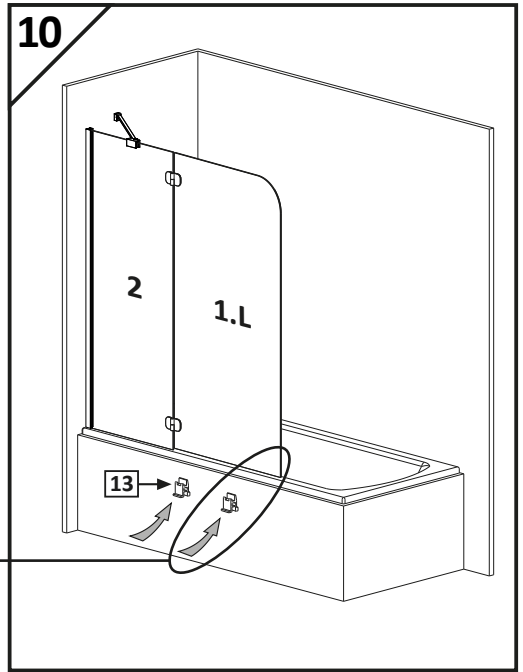
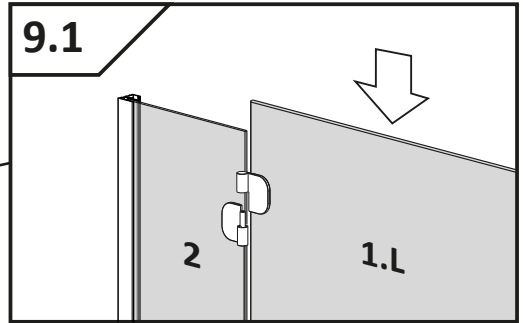
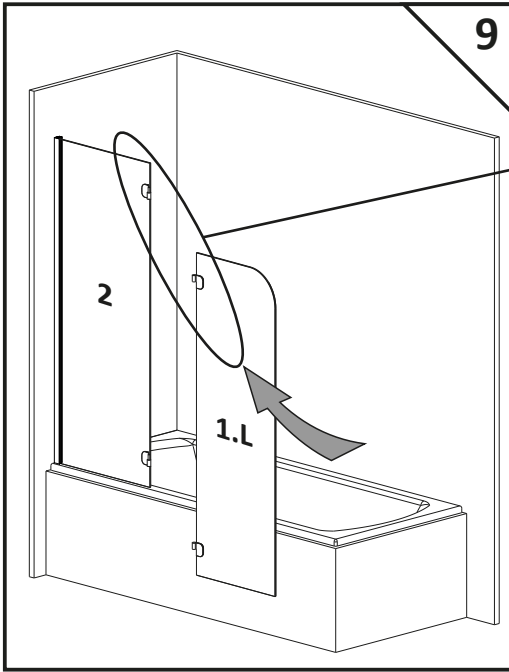

10.3

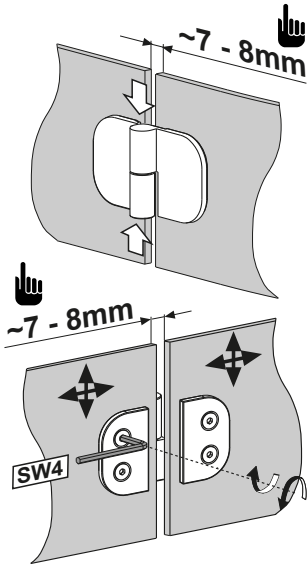

10.4

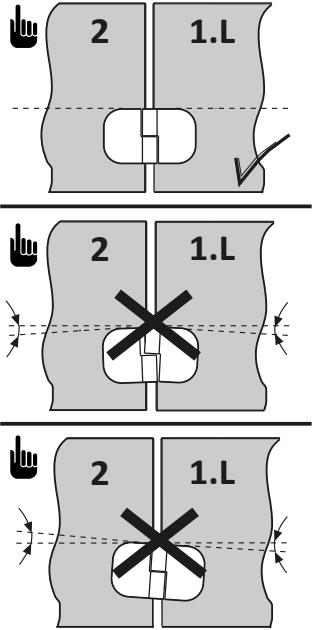

10.5

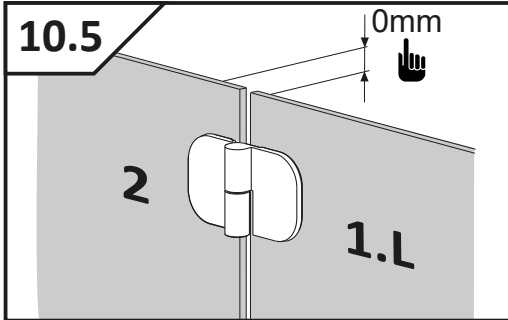

10.6

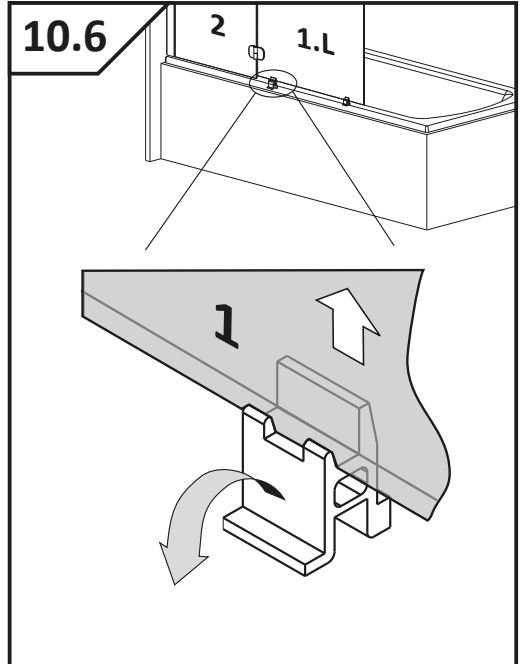

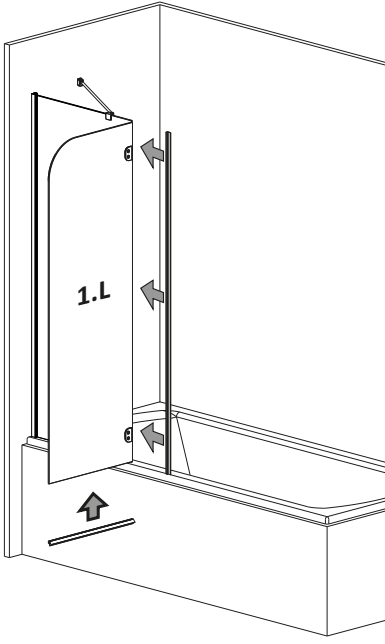
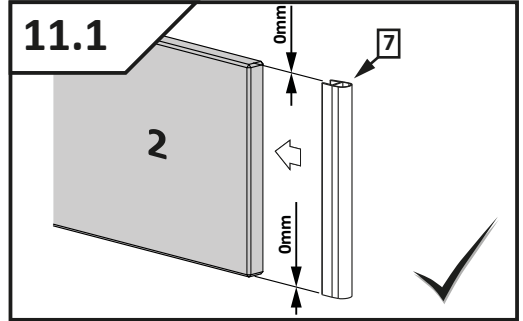
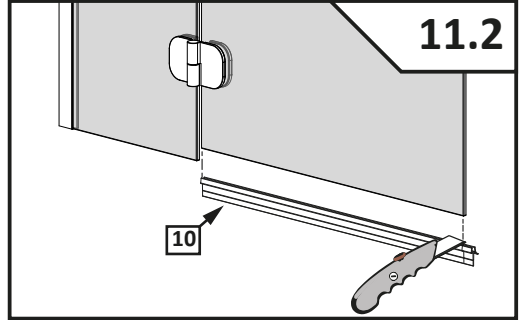
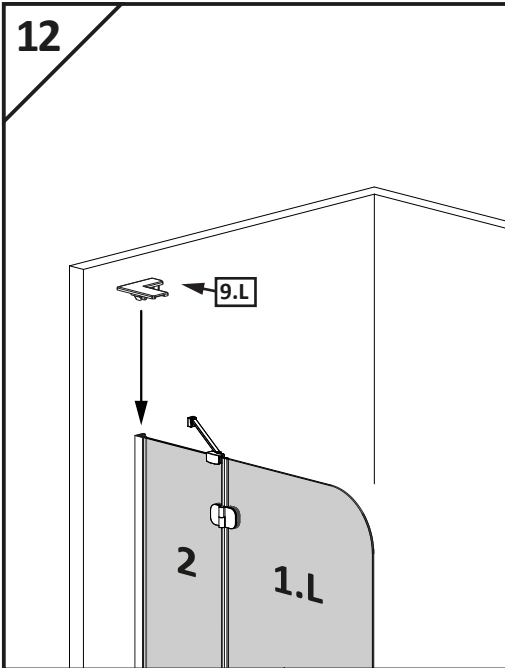
11**11.1****11.2****12****12.1**